

POLARIS

v1.2



AN

Analog measurement barriers



1	Product Description	
1.1	Analog Polaris	3
1.2	Technical Specifications	4
1.2.1	Interpolated detection version	
2	Available Models	
2.1	Interpolated Resolution	5
2.2	Linear Resolution	8
3	Options	
3.1	Mode Selection	11
3.1.1	SL - Internal Selector	
3.1.2	ES - External Selector	
3.2	Sensibility	11
3.2.1	SE - Sensibility Adjustment	
3.2.2	RA - Sensibility Automatic Calibration	
4	Connections	
4.1	Available Connections	12
5	Single output connections with SL	
5.1	5PMExx	13
5.2	8PM12	14
5.3	8PMExx	15
6	Single output connections with ES	
6.1	8PM12	16
6.2	8PMExx	17
7	Double output connections with double SL	
7.1	8PM12	18
7.2	8PMExx	19
8	Characteristics and Identification Code	
8.1	Common Technical Characteristics	20
8.2	Identification Code	20
9	Accessories	
9.1	KPL02 Mounting Bracket Kit	22
9.2	Connecting Cables	22
10	Installation and Adjustments	
10.1	Mechanical Fixing	23
10.2	SE - Sensibility Adjustment	23
10.3	Automatic Calibration procedure for barriers with RA option	24
10.4	Output modes with SL option	25
10.5	Output modes with ES option	26
11	Contacts	

1.1 Analog Polaris

The Polaris system, consisting of a transmitter (TX) and a receiver (RX), generates a grid of parallel beams capable of detecting the presence of objects, determining their position or dimension, and communicating this information to the control system via the 0-10 V (AN1) or 4-20 mA (AN2) output.

Detection is independent of the material and color of the object in transit.

The main applications are:

- Loop control
- Dimension and volume reading
- Packaging
- Painting and lapping plants
- Centering

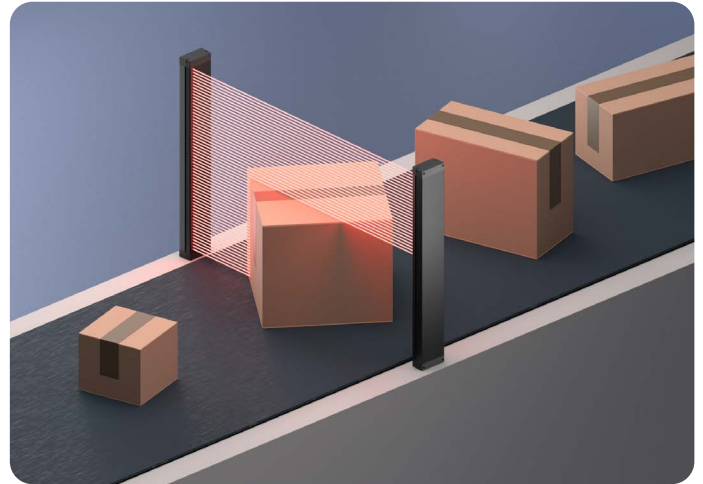

Thanks to an advanced self-calibration system, the barriers with **RA** option are able to easily detect even transparent materials such as glass, transparent sheets and very light fabrics.

The system resolution can be 2.5, 5 or 12 mm interpolated or 10, 24, 48 mm parallel. The detection area cover heights from 80 to 3400 mm with installation ranges from 10 mm to 30 m.

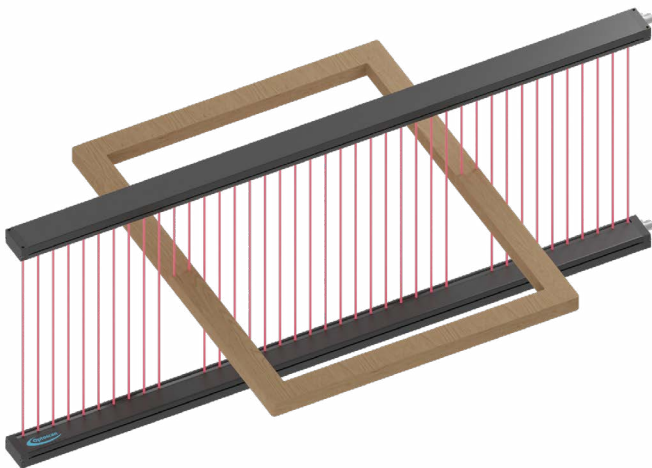

The analog outputs offer four different output modes:

- FIR** (First interrupted ray)
- LIR** (Last interrupted ray)
- i-FIR** (inverted - First interrupted ray)
- TIR** (Total interrupted rays)

To select the output mode, you can use an **external wire** or order the barrier with an internal **DIP switch** (SL).

All control and communication circuits are contained within the barriers, no additional external units are required. Is also available a series with RS485 Modbus digital communication, see [Polaris 485 series](#).

The Polaris series barriers are not safety barriers.

1.2 Technical Specifications

- Resolution:** from 2,5 to 48 mm
- Body dimension:** from 100 to 3476 mm
- Modularity:** from 20, 80, 96 mm based on model
- Protected height:** from 75 to 3435 mm
- Response time:** from 0,7 to 35 ms based on model
- Installation range:** from 10 mm to a 30 m
- Outputs:**
 - 0-10 V + push/pull, 100 mA max;
 - 4-20 mA + push/pull, 100 mA max;
 - 2x 0-10 V + push/pull, 100 mA max;
 - 2x 4-20 mA + push/pull, 100 mA max;
 All outputs are protected from short-circuit
- Light immunity:** 200 Klux until L1, 50 Klux above L1

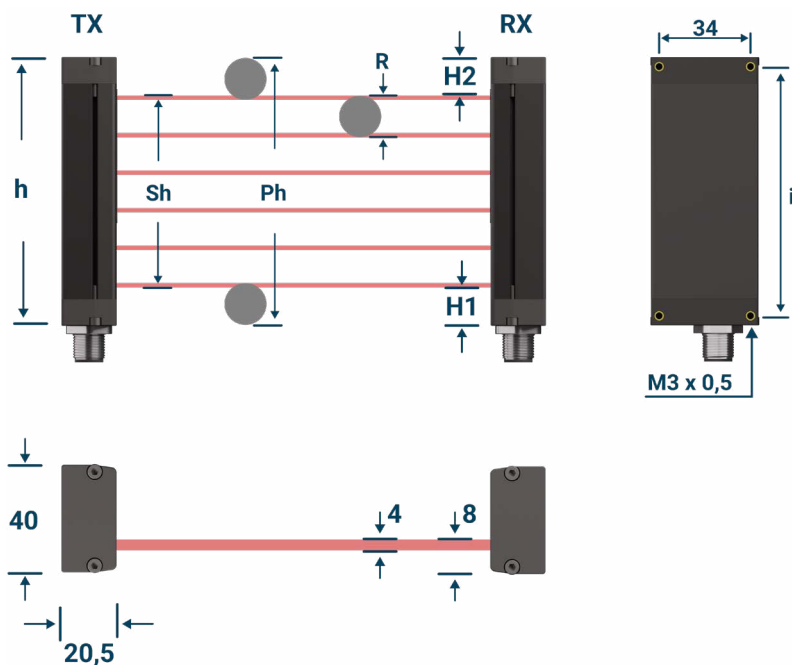

Legend

- h** Body dimension
- Sh** Sensitive height
- Ph** Height of the area where the object is detectable
- R** Resolution: minimal object detected constantly
- H1** Distance between outside and the first beam
- H2** Distance between outside and the last beam
- i** Distance between fixing holes: $h - 7mm$

1.2.1 Interpolated detection version

Thanks to special processing of the received signals, the central area provides twice the number of reading points compared to a traditional parallel beam system.

This scanning mode is particularly suitable for detecting and measuring objects passing through the central area, offering good resolution at a contained cost.

A detailed application note is available on request to define the detection characteristics.

	Beam spacing 2,5 mm	Beam spacing 5 mm	Beam spacing 12 mm
TX	Resolution 5 mm	Resolution 10 mm	Resolution 24 mm
	Resolution 2,5 mm	Resolution 5 mm	Resolution 12 mm
RX	Resolution 5 mm	Resolution 10 mm	Resolution 24 mm

2.1 Interpolated Resolution

Resolution 2,5mm

Models	h	Sh	Ph	H1	H2	i	Maximum scan time (<=L2)	Maximum scan time (>L2)	Number of beams
	Tol.: ±0,5mm	mm	mm	mm	mm	Tol.: ±0,5mm	ms	ms	
PLi 02-80 Lx SEb	100	75	80	13	12	93	0,7	1,1	31
PLi 02-160 Lx SEb	180	155	160	13	12	173	1,2	1,9	63
PLi 02-240 Lx SEb	260	235	240	13	12	253	1,6	2,7	95
PLi 02-320 Lx SEb	340	315	320	13	12	333	2,1	3,5	127
PLi 02-400 Lx SEb	420	395	400	13	12	413	2,5	4,3	159
PLi 02-480 Lx SEb	500	475	480	13	12	493	3,0	5,1	191
PLi 02-560 Lx SEb	580	555	560	13	12	573	3,4	5,9	223
PLi 02-640 Lx SEb	660	635	640	13	12	653	3,9	6,7	255
PLi 02-720 Lx SEb	740	715	720	13	12	733	4,3	7,5	287
PLi 02-800 Lx SEb	820	795	800	13	12	813	4,8	8,3	319
PLi 02-880 Lx SEb	900	875	880	13	12	893	5,2	9,1	351
PLi 02-960 Lx SEb	980	955	960	13	12	973	5,7	9,9	383
PLi 02-1040 Lx SEb	1060	1035	1040	13	12	1053	6,1	10,7	415
PLi 02-1120 Lx SEb	1140	1115	1120	13	12	1133	6,6	11,5	447
PLi 02-1200 Lx SEb	1220	1195	1200	13	12	1213	7,0	12,3	479
PLi 02-1280 Lx SEb	1300	1275	1280	13	12	1293	7,5	13,1	511
PLi 02-1360 Lx SEb	1380	1355	1360	13	12	1373	7,9	13,9	543
PLi 02-1440 Lx SEb	1460	1435	1440	13	12	1453	8,4	14,7	575
PLi 02-1520 Lx SEb	1540	1515	1520	13	12	1533	8,8	15,5	607
PLi 02-1600 Lx SEb	1620	1595	1600	13	12	1613	9,2	16,3	639
PLi 02-1680 Lx SEb	1700	1675	1680	13	12	1693	9,7	17,1	671
PLi 02-1760 Lx SEb	1780	1755	1760	13	12	1773	10,1	17,9	703
PLi 02-1840 Lx SEb	1860	1835	1840	13	12	1853	10,6	18,7	735
PLi 02-1920 Lx SEb	1940	1915	1920	13	12	1933	11,0	19,5	767
PLi 02-2000 Lx SEb	2020	1995	2000	13	12	2013	11,5	20,3	799
PLi 02-2080 Lx SEb	2100	2075	2080	13	12	2093	11,9	21,1	831
PLi 02-2160 Lx SEb	2180	2155	2160	13	12	2173	12,4	21,9	863
PLi 02-2240 Lx SEb	2260	2235	2240	13	12	2253	12,8	22,7	895
PLi 02-2320 Lx SEb	2340	2315	2320	13	12	2333	13,3	23,5	927
PLi 02-2400 Lx SEb	2420	2395	2400	13	12	2413	13,7	24,3	959
PLi 02-2480 Lx SEb	2500	2475	2480	13	12	2493	14,2	25,1	991
PLi 02-2560 Lx SEb	2580	2555	2560	13	12	2573	14,6	25,9	1023
PLi 02-2540 Lx SEb	2660	2635	2640	13	12	2653	15,1	26,7	1055
PLi 02-2640 Lx SEb	2740	2715	2720	13	12	2733	15,5	27,5	1087
PLi 02-2720 Lx SEb	2820	2795	2800	13	12	2813	16,0	28,3	1119
PLi 02-2800 Lx SEb	2900	2875	2880	13	12	2893	16,4	29,1	1151
PLi 02-2960 Lx SEb	2980	2955	2960	13	12	2973	16,9	29,9	1183
PLi 02-3040 Lx SEb	3060	3035	3040	13	12	3053	17,3	30,7	1215
PLi 02-3120 Lx SEb	3140	3115	3120	13	12	3133	17,8	31,5	1247
PLi 02-3200 Lx SEb	3220	3195	3200	13	12	3213	18,2	32,3	1279
PLi 02-3280 Lx SEb	3300	3275	3280	13	12	3293	18,7	33,1	1311
PLi 02-3360 Lx SEb	3380	3355	3360	13	12	3373	19,1	33,9	1343
PLi 02-3440 Lx SEb	3460	3435	3440	13	12	3453	19,6	34,7	1375

Range	
L03	from 10 to 300mm
L05	from 100 to 500mm
L1	from 200 to 1000mm
L2	from 200 to 2000mm
L4	from 500 to 4000mm

Resolution 5mm

Models	h	Sh	Ph	H1	H2	i	Maximum scan time (<=L2)	Maximum scan time (>L2)	Number of beams
	Tol.: ±0,5mm	mm	mm	mm	mm	Tol.: ±0,5mm	ms	ms	
PLi 05-80 Lx	100	71	81	14	15	93	0,6	1,0	15
PLi 05-100 Lx	120	91	101	14	15	113	0,7	1,2	19
PLi 05-120 Lx	140	111	121	14	15	133	0,8	1,4	23
PLi 05-140 Lx	160	131	141	14	15	153	1,0	1,6	27
PLi 05-160 Lx	180	151	161	14	15	173	1,1	1,8	31
PLi 05-180 Lx	200	171	181	14	15	193	1,2	2,0	35
PLi 05-200 Lx	220	191	201	14	15	213	1,3	2,2	39
PLi 05-220 Lx	240	211	221	14	15	233	1,4	2,4	43
PLi 05-240 Lx	260	231	241	14	15	253	1,5	2,6	47
PLi 05-260 Lx	280	251	261	14	15	273	1,6	2,8	51
PLi 05-280 Lx	300	271	281	14	15	293	1,7	3,0	55
PLi 05-300 Lx	320	291	301	14	15	313	1,9	3,2	59
PLi 05-320 Lx	340	311	321	14	15	333	2,0	3,4	63
PLi 05-400 Lx	420	391	401	14	15	413	2,4	4,2	79
PLi 05-480 Lx	500	471	481	14	15	493	2,9	5,0	95
PLi 05-560 Lx	580	551	561	14	15	573	3,3	5,8	111
PLi 05-640 Lx	660	631	641	14	15	653	3,8	6,6	127
PLi 05-720 Lx	740	711	721	14	15	733	4,2	7,4	143
PLi 05-800 Lx	820	791	801	14	15	813	4,7	8,2	159
PLi 05-880 Lx	900	871	881	14	15	893	5,1	9,0	175
PLi 05-960 Lx	980	951	961	14	15	973	5,5	9,8	191
PLi 05-1040 Lx	1060	1031	1041	14	15	1053	6,0	10,6	207
PLi 05-1120 Lx	1140	1111	1121	14	15	1133	6,4	11,4	223
PLi 05-1200 Lx	1220	1191	1201	14	15	1213	6,9	12,2	239
PLi 05-1280 Lx	1300	1271	1281	14	15	1293	7,3	13,0	255
PLi 05-1360 Lx	1380	1351	1361	14	15	1373	7,8	13,8	271
PLi 05-1440 Lx	1460	1431	1441	14	15	1453	8,2	14,6	287
PLi 05-1520 Lx	1540	1511	1521	14	15	1533	8,7	15,4	303
PLi 05-1600 Lx	1620	1591	1601	14	15	1613	9,1	16,2	319
PLi 05-1680 Lx	1700	1671	1681	14	15	1693	9,6	17,0	335
PLi 05-1760 Lx	1780	1751	1761	14	15	1773	10,0	17,8	351
PLi 05-1840 Lx	1860	1831	1841	14	15	1853	10,5	18,6	367
PLi 05-1920 Lx	1940	1911	1921	14	15	1933	10,9	19,4	383
PLi 05-2000 Lx	2020	1991	2001	14	15	2013	11,4	20,2	399
PLi 05-2080 Lx	2100	2071	2081	14	15	2093	11,8	21,0	415
PLi 05-2160 Lx	2180	2151	2161	14	15	2173	12,3	21,8	431
PLi 05-2240 Lx	2260	2231	2241	14	15	2253	12,7	22,6	447
PLi 05-2320 Lx	2340	2311	2321	14	15	2333	13,2	23,4	463
PLi 05-2400 Lx	2420	2391	2401	14	15	2413	13,6	24,2	479
PLi 05-2480 Lx	2500	2471	2481	14	15	2493	14,1	25,0	495
PLi 05-2560 Lx	2580	2551	2561	14	15	2573	14,5	25,8	511
PLi 05-2540 Lx	2660	2631	2641	14	15	2653	15,0	26,6	527
PLi 05-2640 Lx	2740	2711	2721	14	15	2733	15,4	27,4	543
PLi 05-2720 Lx	2820	2791	2801	14	15	2813	15,9	28,2	559
PLi 05-2800 Lx	2900	2871	2881	14	15	2893	16,3	29,0	575
PLi 05-2960 Lx	2980	2951	2961	14	15	2973	16,7	29,8	591
PLi 05-3040 Lx	3060	3031	3041	14	15	3053	17,2	30,6	607
PLi 05-3120 Lx	3140	3111	3121	14	15	3133	17,6	31,4	623
PLi 05-3200 Lx	3220	3191	3201	14	15	3213	18,1	32,2	639
PLi 05-3280 Lx	3300	3271	3281	14	15	3293	18,5	33,0	655
PLi 05-3360 Lx	3380	3351	3361	14	15	3373	19,0	33,8	671
PLi 05-3440 Lx	3460	3431	3441	14	15	3453	19,4	34,6	687

Range	
L03	from 10 to 300mm
L05	from 100 to 500mm
L1	from 200 to 1000mm
L2	from 200 to 2000mm
L4	from 500 to 4000mm
L6	from 500 to 6000mm
L8	from 500 to 8000mm

Resolution 12mm

Models	h	Sh	Ph	H1	H2	i	Maximum scan time (<=L2)	Maximum scan time (>L2)	Number of beams
	Tol.: ±0,5mm	mm	mm	mm	mm	Tol.: ±0,5mm	ms	ms	
PLi 12-095 Lx	116	72	96	22	22	109	0,4	0,6	7
PLi 12-190 Lx	212	168	192	22	22	205	0,6	1,0	15
PLi 12-290 Lx	308	264	288	22	22	301	0,8	1,4	23
PLi 12-380 Lx	404	360	384	22	22	397	1,1	1,8	31
PLi 12-480 Lx	500	456	480	22	22	493	1,3	2,2	39
PLi 12-580 Lx	596	552	576	22	22	589	1,5	2,6	47
PLi 12-670 Lx	692	648	672	22	22	685	1,7	3,0	55
PLi 12-770 Lx	788	744	768	22	22	781	2,0	3,4	63
PLi 12-860 Lx	884	840	864	22	22	877	2,2	3,8	71
PLi 12-960 Lx	980	936	960	22	22	973	2,4	4,2	79
PLi 12-1060 Lx	1076	1032	1056	22	22	1069	2,6	4,6	87
PLi 12-1150 Lx	1172	1128	1152	22	22	1165	2,9	5,0	95
PLi 12-1250 Lx	1268	1224	1248	22	22	1261	3,1	5,4	103
PLi 12-1340 Lx	1364	1320	1344	22	22	1357	3,3	5,8	111
PLi 12-1440 Lx	1460	1416	1440	22	22	1453	3,5	6,2	119
PLi 12-1540 Lx	1556	1512	1536	22	22	1549	3,8	6,6	127
PLi 12-1630 Lx	1652	1608	1632	22	22	1645	4,0	7,0	135
PLi 12-1730 Lx	1748	1704	1728	22	22	1741	4,2	7,4	143
PLi 12-1820 Lx	1844	1800	1824	22	22	1837	4,4	7,8	151
PLi 12-1920 Lx	1940	1896	1920	22	22	1933	4,7	8,2	159
PLi 12-2020 Lx	2036	1992	2016	22	22	2029	4,9	8,6	167
PLi 12-2120 Lx	2132	2088	2112	22	22	2125	5,1	9,0	175
PLi 12-2210 Lx	2228	2184	2208	22	22	2221	5,3	9,4	183
PLi 12-2300 Lx	2324	2280	2304	22	22	2317	5,5	9,8	191
PLi 12-2400 Lx	2420	2376	2400	22	22	2413	5,8	10,2	199
PLi 12-2500 Lx	2516	2472	2496	22	22	2509	6,0	10,6	207
PLi 12-2600 Lx	2612	2568	2592	22	22	2605	6,2	11,0	215
PLi 12-2700 Lx	2708	2664	2688	22	22	2701	6,4	11,4	223
PLi 12-2800 Lx	2804	2760	2784	22	22	2797	6,7	11,8	231
PLi 12-2900 Lx	2900	2856	2880	22	22	2893	6,9	12,2	239
PLi 12-3000 Lx	2996	2952	2976	22	22	2989	7,1	12,6	247
PLi 12-3100 Lx	3092	3048	3072	22	22	3085	7,3	13,0	255
PLi 12-3200 Lx	3188	3144	3168	22	22	3181	7,6	13,4	263
PLi 12-3300 Lx	3284	3240	3264	22	22	3277	7,8	13,8	271
PLi 12-3400 Lx	3380	3336	3360	22	22	3373	8,0	14,2	279
PLi 12-3500 Lx	3476	3432	3456	22	22	3469	8,2	14,6	287

Range	
L03	from 10 to 300mm
L05	from 100 to 500mm
L1	from 200 to 1000mm
L2	from 200 to 2000mm
L4	from 500 to 4000mm
L6	from 500 to 6000mm
L8	from 500 to 8000mm

2.2 Linear Resolution

Resolution 10mm

Models	h	Sh	Ph	H1	H2	i	Maximum scan time (<=L2)	Maximum scan time (>L2)	Number of beams
	Tol.: ±0,5mm	mm	mm	mm	mm	Tol.: ±0,5mm	ms	ms	
PL 10-80 Lx	100	71	91	14	15	93	0,4	0,6	8
PL 10-100 Lx	120	91	111	14	15	113	0,5	0,7	10
PL 10-120 Lx	140	111	131	14	15	133	0,5	0,8	12
PL 10-140 Lx	160	131	151	14	15	153	0,6	0,9	14
PL 10-160 Lx	180	151	171	14	15	173	0,6	1,0	16
PL 10-180 Lx	200	171	191	14	15	193	0,7	1,1	18
PL 10-200 Lx	220	191	211	14	15	213	0,8	1,2	20
PL 10-220 Lx	240	211	231	14	15	233	0,8	1,3	22
PL 10-240 Lx	260	231	251	14	15	253	0,9	1,4	24
PL 10-260 Lx	280	251	271	14	15	273	0,9	1,5	26
PL 10-280 Lx	300	271	291	14	15	293	1,0	1,6	28
PL 10-300 Lx	320	291	311	14	15	313	1,0	1,7	30
PL 10-320 Lx	340	311	331	14	15	333	1,1	1,8	32
PL 10-400 Lx	420	391	411	14	15	413	1,3	2,2	40
PL 10-480 Lx	500	471	491	14	15	493	1,5	2,6	48
PL10-500 Lx	520	491	511	14	15	513	1,6	2,7	50
PL 10-560 Lx	580	551	571	14	15	573	1,8	3,0	56
PL 10-640 Lx	660	631	651	14	15	653	2,0	3,4	64
PL 10-720 Lx	740	711	731	14	15	733	2,2	3,8	72
PL 10-800 Lx	820	791	811	14	15	813	2,4	4,2	80
PL 10-880 Lx	900	871	891	14	15	893	2,7	4,6	88
PL 10-960 Lx	980	951	971	14	15	973	2,9	5,0	96
PL 10-1040 Lx	1060	1031	1051	14	15	1053	3,1	5,4	104
PL 10-1120 Lx	1140	1111	1131	14	15	1133	3,3	5,8	112
PL 10-1200 Lx	1220	1191	1211	14	15	1213	3,6	6,2	120
PL 10-1280 Lx	1300	1271	1291	14	15	1293	3,8	6,6	128
PL 10-1360 Lx	1380	1351	1371	14	15	1373	4,0	7,0	136
PL 10-1440 Lx	1460	1431	1451	14	15	1453	4,2	7,4	144
PL 10-1520 Lx	1540	1511	1531	14	15	1533	4,5	7,8	152
PL 10-1600 Lx	1620	1591	1611	14	15	1613	4,7	8,2	160
PL 10-1680 Lx	1700	1671	1691	14	15	1693	4,9	8,6	168
PL 10-1760 Lx	1780	1751	1771	14	15	1773	5,1	9,0	176
PL 10-1840 Lx	1860	1831	1851	14	15	1853	5,4	9,4	184
PL 10-1920 Lx	1940	1911	1931	14	15	1933	5,6	9,8	192
PL 10-2000 Lx	2020	1991	2011	14	15	2013	5,8	10,2	200
PL 10-2080 Lx	2100	2071	2091	14	15	2093	6,0	10,6	208
PL 10-2160 Lx	2180	2151	2171	14	15	2173	6,2	11,0	216
PL 10-2240 Lx	2260	2231	2251	14	15	2253	6,5	11,4	224
PL 10-2320 Lx	2340	2311	2331	14	15	2333	6,7	11,8	232
PL 10-2400 Lx	2420	2391	2411	14	15	2413	6,9	12,2	240
PL 10-2480 Lx	2500	2471	2491	14	15	2493	7,1	12,6	248
PL 10-2560 Lx	2580	2551	2571	14	15	2573	7,4	13,0	256
PL 10-2640 Lx	2660	2631	2651	14	15	2653	7,6	13,4	264
PL 10-2720 Lx	2740	2711	2731	14	15	2733	7,8	13,8	272
PL 10-2800 Lx	2820	2791	2811	14	15	2813	8,0	14,2	280
PL 10-2880 Lx	2900	2871	2891	14	15	2893	8,3	14,6	288
PL 10-2960 Lx	2980	2951	2971	14	15	2973	8,5	15,0	296
PL 10-3040 Lx	3060	3031	3051	14	15	3053	8,7	15,4	304
PL 10-3120 Lx	3140	3111	3131	14	15	3133	8,9	15,8	312
PL 10-3200 Lx	3220	3191	3211	14	15	3213	9,2	16,2	320
PL 10-3280 Lx	3300	3271	3291	14	15	3293	9,4	16,6	328
PL 10-3360 Lx	3380	3351	3371	14	15	3373	9,6	17,0	336
PL 10-3440 Lx	3460	3431	3451	14	15	3453	9,8	17,4	344

Range	
L03	from 10 to 300mm
L05	from 100 to 500mm
L1	from 200 to 1000mm
L2	from 200 to 2000mm
L4	from 500 to 4000mm
L6	from 500 to 6000mm
L8	from 500 to 8000mm

Resolution 24mm

Models	h	Sh	Ph	H1	H2	i	Maximum scan time (<=L2)	Maximum scan time (>L2)	Number of beams
	Tol.: ±0,5mm	mm	mm	mm	mm	Tol.: ±0,5mm	ms	ms	
PL 24-095 Lx	116	72	120	22	22	109	0,3	0,4	4
PL 24-190 Lx	212	168	216	22	22	205	0,4	0,6	8
PL 24-290 Lx	308	264	312	22	22	301	0,5	0,8	12
PL 24-380 Lx	404	360	408	22	22	397	0,6	1,0	16
PL 24-480 Lx	500	456	504	22	22	493	0,8	1,2	20
PL 24-580 Lx	596	552	600	22	22	589	0,9	1,4	24
PL 24-670 Lx	692	648	696	22	22	685	1,0	1,6	28
PL 24-770 Lx	788	744	792	22	22	781	1,1	1,8	32
PL 24-860 Lx	884	840	888	22	22	877	1,2	2,0	36
PL 24-960 Lx	980	936	984	22	22	973	1,3	2,2	40
PL 24-1060 Lx	1076	1032	1080	22	22	1069	1,4	2,4	44
PL 24-1150 Lx	1172	1128	1176	22	22	1165	1,5	2,6	48
PL 24-1250 Lx	1268	1224	1272	22	22	1261	1,7	2,8	52
PL 24-1340 Lx	1364	1320	1368	22	22	1357	1,8	3,0	56
PL 24-1440 Lx	1460	1416	1464	22	22	1453	1,9	3,2	60
PL 24-1540 Lx	1556	1512	1560	22	22	1549	2,0	3,4	64
PL 24-1630 Lx	1652	1608	1656	22	22	1645	2,1	3,6	68
PL 24-1730 Lx	1748	1704	1752	22	22	1741	2,2	3,8	72
PL 24-1820 Lx	1844	1800	1848	22	22	1837	2,3	4,0	76
PL 24-1920 Lx	1940	1896	1944	22	22	1933	2,4	4,2	80
PL 24-2020 Lx	2036	1992	2040	22	22	2029	2,6	4,4	84
PL 24-2120 Lx	2132	2088	2136	22	22	2125	2,7	4,6	88
PL 24-2210 Lx	2228	2184	2232	22	22	2221	2,8	4,8	92
PL 24-2300 Lx	2324	2280	2328	22	22	2317	2,9	5,0	96
PL 24-2400 Lx	2420	2376	2424	22	22	2413	3,0	5,2	100
PL 24-2500 Lx	2516	2472	2520	22	22	2509	3,1	5,4	104
PL 24-2600 Lx	2612	2568	2616	22	22	2605	3,2	5,6	108
PL 24-2700 Lx	2708	2664	2712	22	22	2701	3,3	5,8	112
PL 24-2800 Lx	2804	2760	2808	22	22	2797	3,4	6,0	116
PL 24-2900 Lx	2900	2856	2904	22	22	2893	3,6	6,2	120
PL 24-3000 Lx	2996	2952	3000	22	22	2989	3,7	6,4	124
PL 24-3100 Lx	3092	3048	3096	22	22	3085	3,8	6,6	128
PL 24-3200 Lx	3188	3144	3192	22	22	3181	3,9	6,8	132
PL 24-3300 Lx	3284	3240	3288	22	22	3277	4,0	7,0	136
PL 24-3400 Lx	3380	3336	3384	22	22	3373	4,1	7,2	140
PL 24-3500 Lx	3476	3432	3480	22	22	3469	4,2	7,4	144

Range	
L03	from 10 to 300mm
L05	from 100 to 500mm
L1	from 200 to 1000mm
L2	from 200 to 2000mm
L4	from 500 to 4000mm
L6	from 500 to 6000mm
L8	from 500 to 8000mm

Resolution 48mm

Models	h	Sh	Ph	H1	H2	i	Maximum scan time (<=L2)	Maximum scan time (>L2)	Number of beams
	Tol.: ±0,5mm	mm	mm	mm	mm	Tol.: ±0,5mm	ms	ms	
PL 48-190 Lx	212	144	240	22	46	205	0,3	0,4	4
PL 48-380 Lx	404	336	432	22	46	397	0,4	0,6	8
PL 48-580 Lx	596	528	624	22	46	589	0,5	0,8	12
PL 48-770 Lx	788	720	816	22	46	781	0,6	1,0	16
PL 48-960 Lx	980	912	1008	22	46	973	0,8	1,2	20
PL 48-1150 Lx	1172	1104	1200	22	46	1165	0,9	1,4	24
PL 48-1340 Lx	1364	1296	1392	22	46	1357	1,0	1,6	28
PL 48-1540 Lx	1556	1488	1584	22	46	1549	1,1	1,8	32
PL 48-1730 Lx	1748	1680	1776	22	46	1741	1,2	2,0	36
PL 48-1920 Lx	1940	1872	1968	22	46	1933	1,3	2,2	40
PL 48-2120 Lx	2132	2064	2160	22	46	2125	1,4	2,4	44
PL 48-2300 Lx	2324	2256	2352	22	46	2317	1,5	2,6	48
PL 48-2500 Lx	2516	2448	2544	22	46	2509	1,7	2,8	52
PL 48-2700 Lx	2708	2640	2736	22	46	2701	1,8	3,0	56
PL 48-2900 Lx	2900	2832	2928	22	46	2893	1,9	3,2	60

Range	
L03	from 10 to 300mm
L05	from 100 to 500mm
L1	from 200 to 1000mm
L2	from 200 to 2000mm
L4	from 500 to 4000mm
L6	from 500 to 6000mm
L8	from 500 to 8000mm
L15	from 1 to 15m
L30	from 1 to 30m

3.1 Mode Selection

3.1.1 SL - Internal Selector

Thanks to the **DIP switch** on the receiver it is possible to set four operating modes that provide information about the size of the object or its position. More information in the [Output modes with SL option](#) section of the document.

With the SL option two switches (on the single output version) or four switches (on the dual output version) allows you to choose the configuration by yourself.

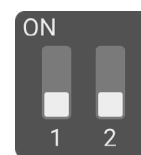

3.1.2 ES - External Selector

Thanks to the **external wire** is possible to set three different operating modes that provide information about the size of the object or its position. More information in the [Output modes with ES option](#) section of the document.

3.2 Sensibility

3.2.1 SE - Sensibility Adjustment

It is necessary in case of detection at the limit of resolution and in case of detection of transparencies. It can be ordered in three different positions: bottom (SEb), front (SEa), rear (SEp).



SEb - Bottom adjustment

The bottom adjustment is standard.



SEa - Front adjustment

The front adjustment replaces the bottom adjustment in case of customer's need.



SEp - Rear adjustment

The rear adjustment replaces the bottom adjustment in case of customer's need.

3.2.2 RA - Sensibility Automatic Calibration

Polaris with the **RA** option, thanks to an advanced automatic calibration technology, allow the reading of transparent films, overlapping of transparent sheets, light fabrics, nets, and loop control of wires starting from **0.2mm** in diameter.

Barriers with the **PN** option provide one 0-24V output activated when an object is detected or in case of overlapping transparent sheets (not available with the **5PME** connection).

The combination of the two options, **RA** and **PN**, is used for the detection of holes during the production of **stretch film** even at speeds of over 1000 m/min.

The RA option features the trimmer positioned at the bottom (**RAb**). However, upon request, the trimmer can be configured in either a front (**RAa**) or rear (**RAp**) position.

More information in the [Automatic Calibration](#) section of the document.

4.1 Available Connections

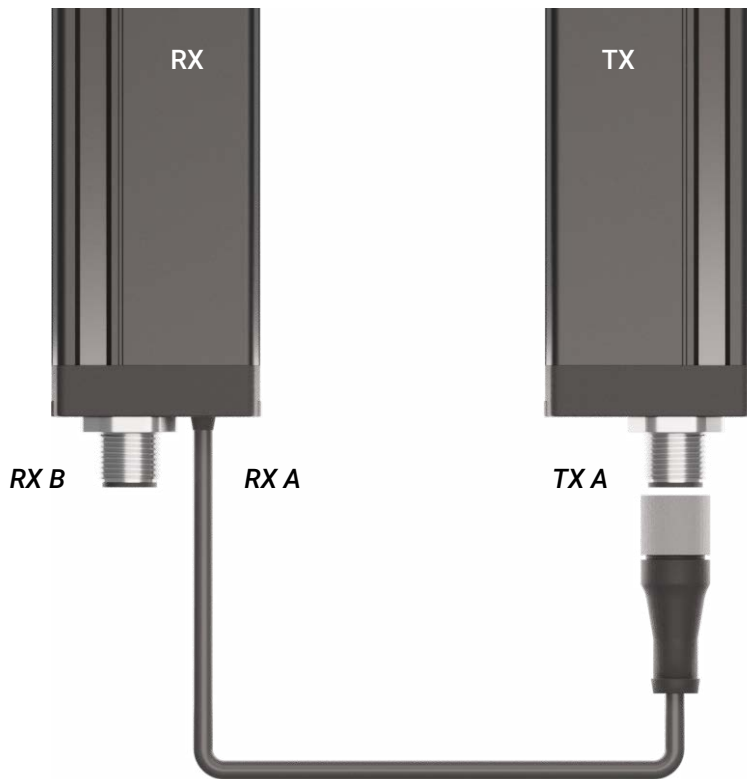
**5PME/8PME connection**

The **RX B** connector is M12 male.

5PME, 5 pins.

8PME, 8 pins.

The choice of connector depends on the required functions.

The **TX A - RX A** interconnection is made via a cable with an M12 female connector of length xx cm.

This is the optimal solution for short distances between TX and RX.

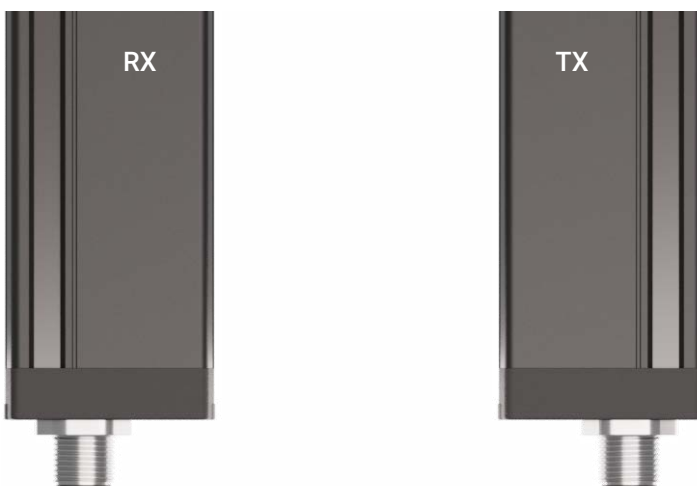
**8PM12 connection**

RX: M12 male, 8 pins.

TX: M12 male, 4 pins.

5.1 5PME

SL AN1 PN 5PME or SL AN2 PN 5PME

One analog output + PNP/NPN output, with interconnection cable.

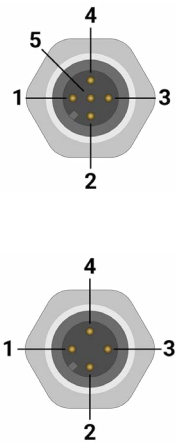

Pin	Colour	RX
1	Brown	+24Vdc
2	White	Analog output
3	Blue	0 Vdc
4	Black	Out PNP + NPN
5	Grey	Analog GND

Pin	Colour	TX
1	Brown	+ 24 Vdc
2	White	Sync 1
3	Blue	0 Vdc
4	Black	Sync 2

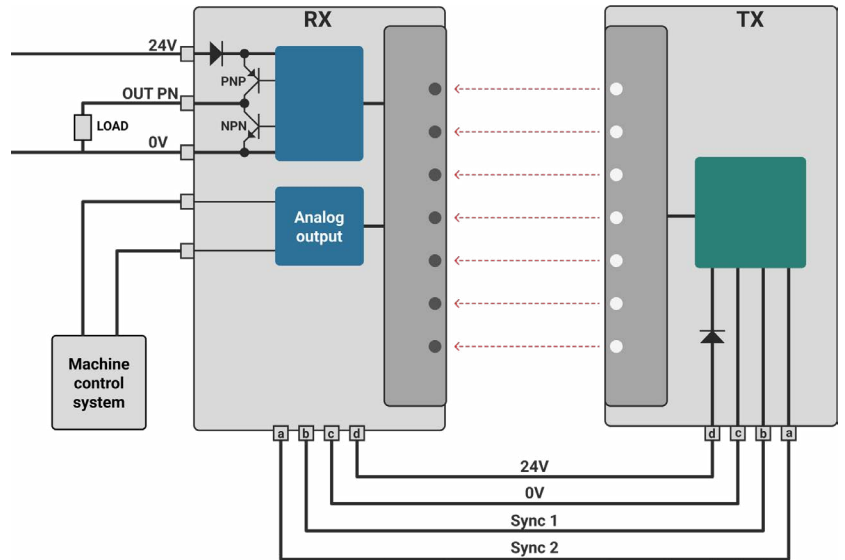

RA SL AN1 5PME or RA SL AN2 5PME

One analog output + Auto-Calibration input, with interconnection cable.

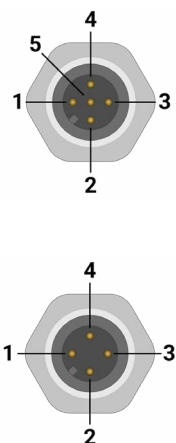

Pin	Colour	RX
1	Brown	+24Vdc
2	White	Analog output
3	Blue	0 Vdc
4	Black	Auto-Cal
5	Grey	Analog GND

Pin	Colour	TX
1	Brown	+ 24 Vdc
2	White	Sync 1
3	Blue	0 Vdc
4	Black	Sync 2

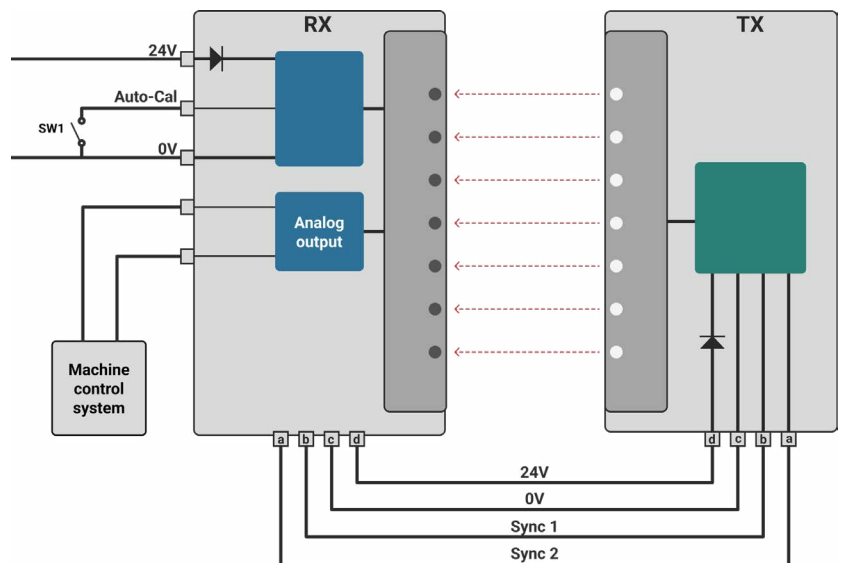

PN outputs not available

5.2 8PM12

RA SL AN1 PN 8PM12 or RA SL AN2 PN 8PM12

One analog output + PNP/NPN output + Auto-Calibration input.

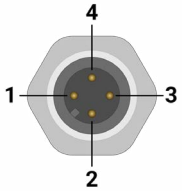
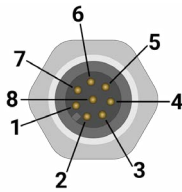

Pin	Colour	RX
1	White	Analog output
2	Brown	+24Vdc
3	Green	Out PNP + NPN
4	Yellow	Auto-Cal
5	Grey	Analog GND
6	Pink	Sync 1
7	Blue	0 Vdc
8	Red	Sync 2

Pin	Colour	TX
1	Brown	+ 24 Vdc
2	White	Sync 1
3	Blue	0 Vdc
4	Black	Sync 2

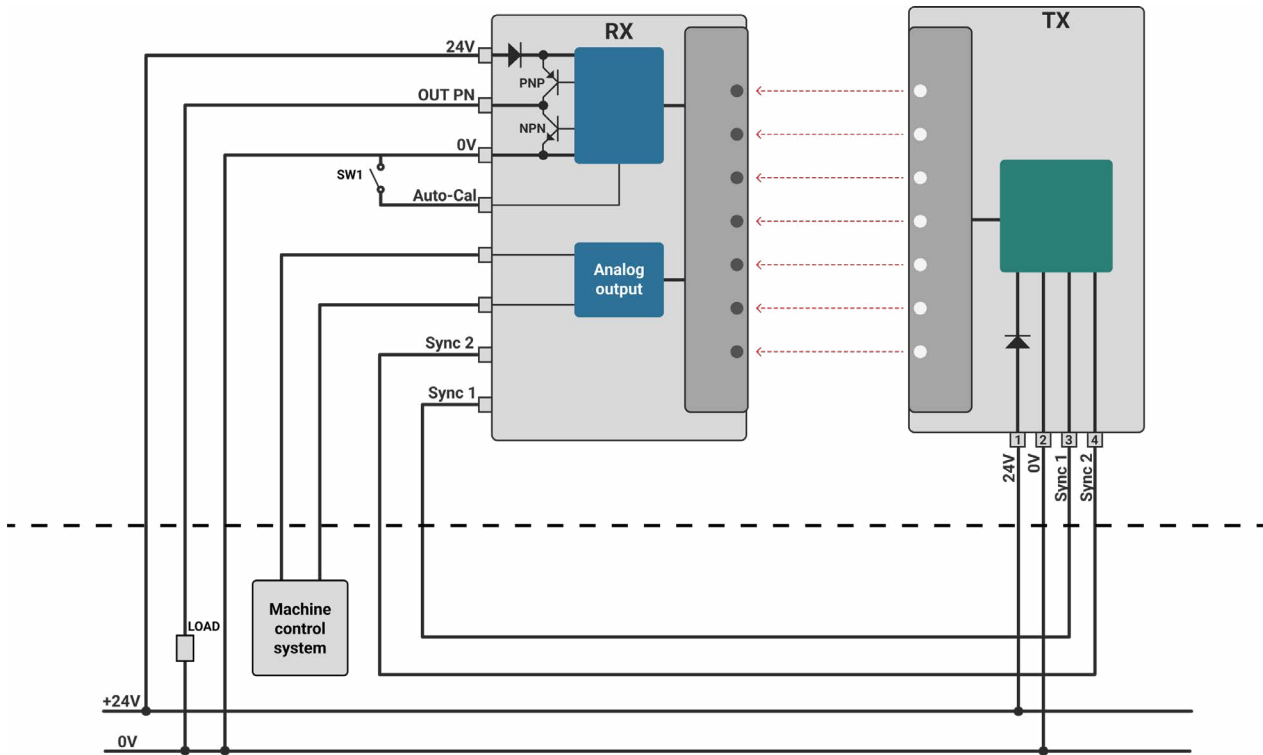

5.3 8PME

RA SL AN1 PN 8PME or RA SL AN2 PN 8PME

One analog output + PNP/NPN output + Auto-Calibration input, with interconnection cable.

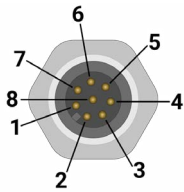

Pin	Colour	RX
1	White	Analog output
2	Brown	+24Vdc
3	Green	Out PNP + NPN
4	Yellow	Auto-Cal
5	Grey	Analog GND
6	Pink	
7	Blue	0 Vdc
8	Red	

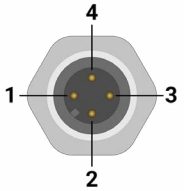

Pin	Colour	TX
1	Brown	+ 24 Vdc
2	White	Sync 1
3	Blue	0 Vdc
4	Black	Sync 2

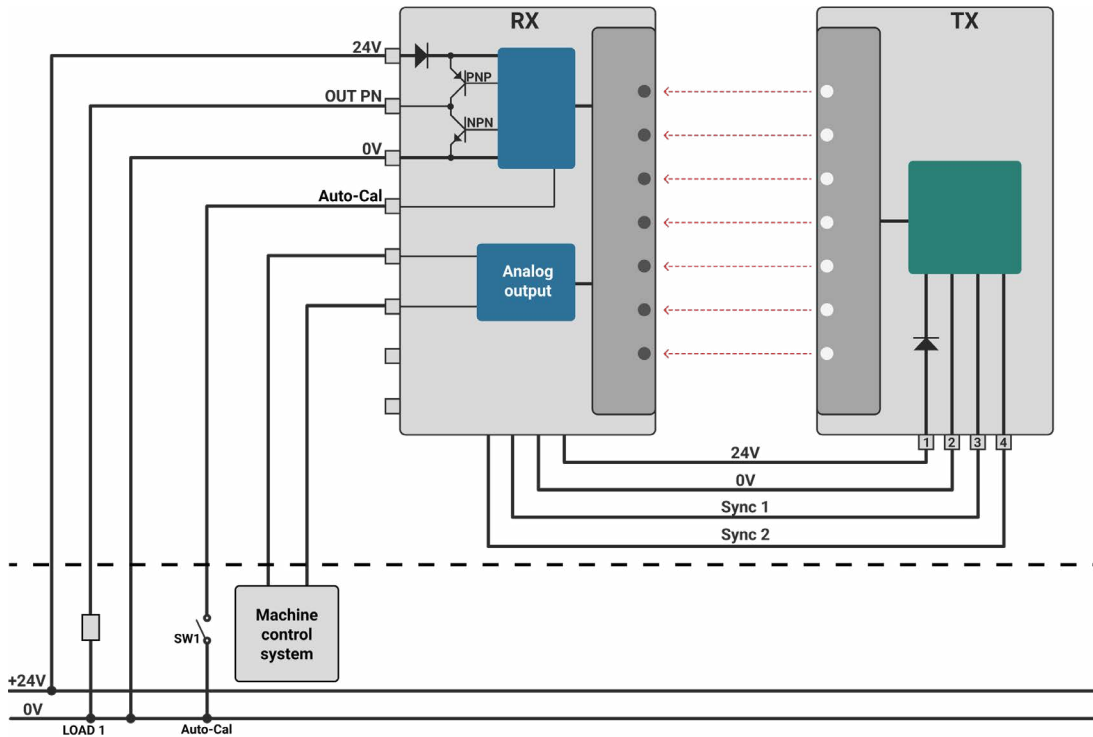

6.1 8PM12

ES AN1 PN 8PM12 or ES AN2 PN 8PM12

One analog output + PNP/NPN output + output mode selector input.

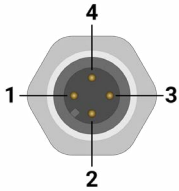
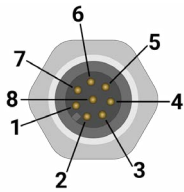

Pin	Colour	RX
1	White	Analog output
2	Brown	+24Vdc
3	Green	Out PNP + NPN
4	Yellow	ES
5	Grey	Analog GND
6	Pink	Sync 1
7	Blue	0 Vdc
8	Red	Sync 2

Pin	Colour	TX
1	Brown	+ 24 Vdc
2	White	Sync 1
3	Blue	0 Vdc
4	Black	Sync 2

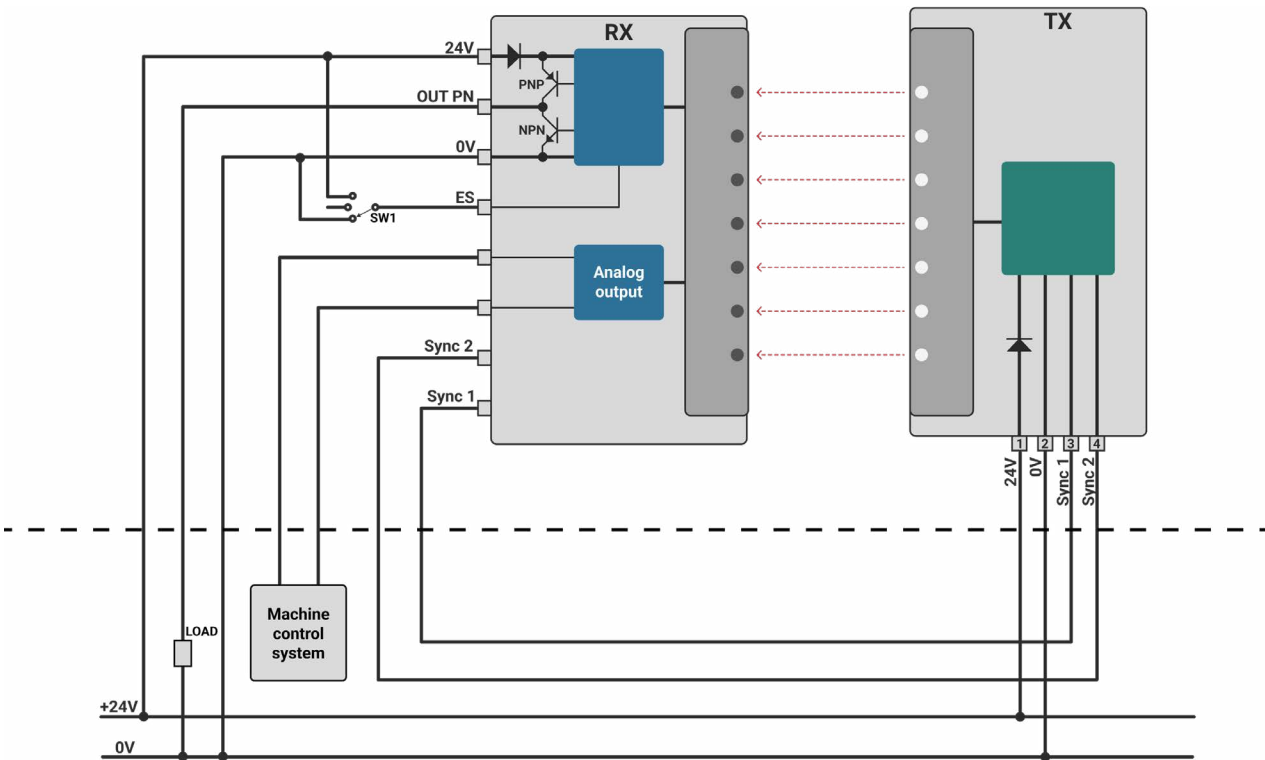

6.2 8PME

RA ES AN1 PN 8PME or RA ES AN2 PN 8PME

One analog output + PNP/NPN output + Auto-Calibration input + output mode selector input, with interconnection cable.

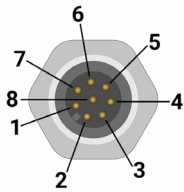

Pin	Colour	RX
1	White	Analog output
2	Brown	+24Vdc
3	Green	Out PNP + NPN
4	Yellow	Auto-Cal
5	Grey	Analog GND
6	Pink	ES
7	Blue	0 Vdc
8	Red	

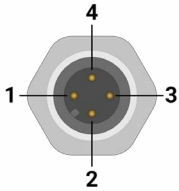

Pin	Colour	TX
1	Brown	+ 24 Vdc
2	White	Sync 1
3	Blue	0 Vdc
4	Black	Sync 2

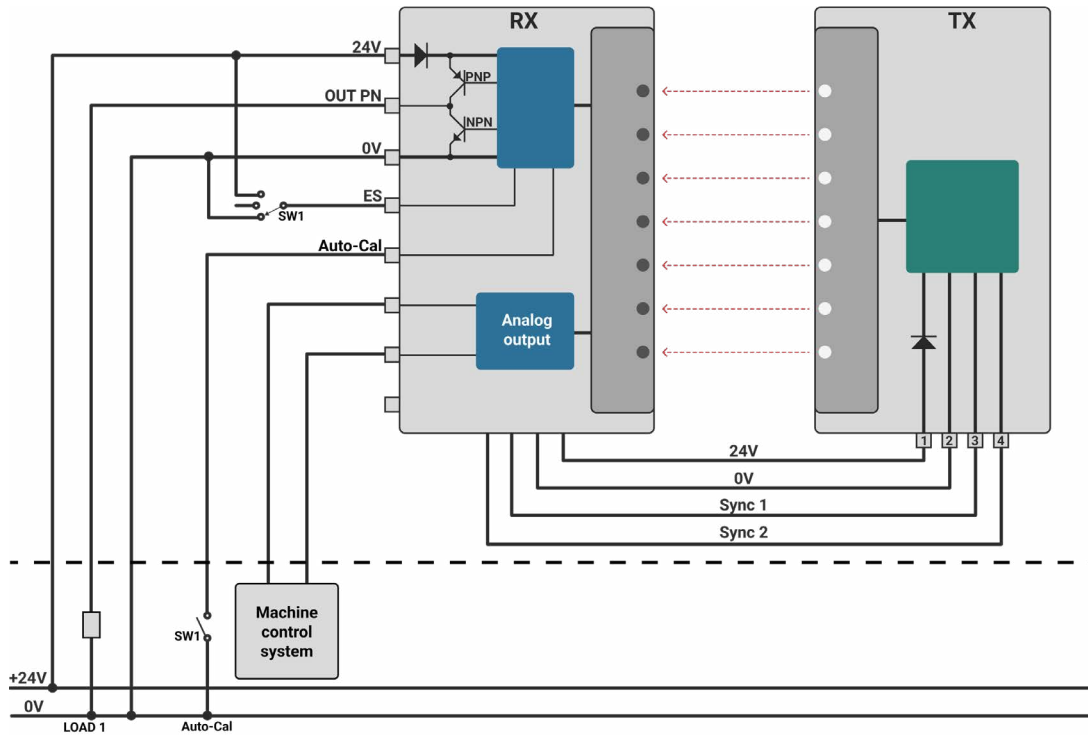

7.1 8PM12

SL 2AN1 PN 8PM12 or SL 2AN2 PN 8PM12

Two analog outputs + PNP/NPN output.

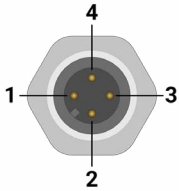
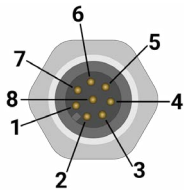

Pin	Colour	RX
1	White	Analog output 1
2	Brown	+24Vdc
3	Green	Out PNP + NPN
4	Yellow	Analog output 2
5	Grey	Analog GND
6	Pink	Sync 1
7	Blue	0 Vdc
8	Red	Sync 2

Pin	Colour	TX
1	Brown	+ 24 Vdc
2	White	Sync 1
3	Blue	0 Vdc
4	Black	Sync 2

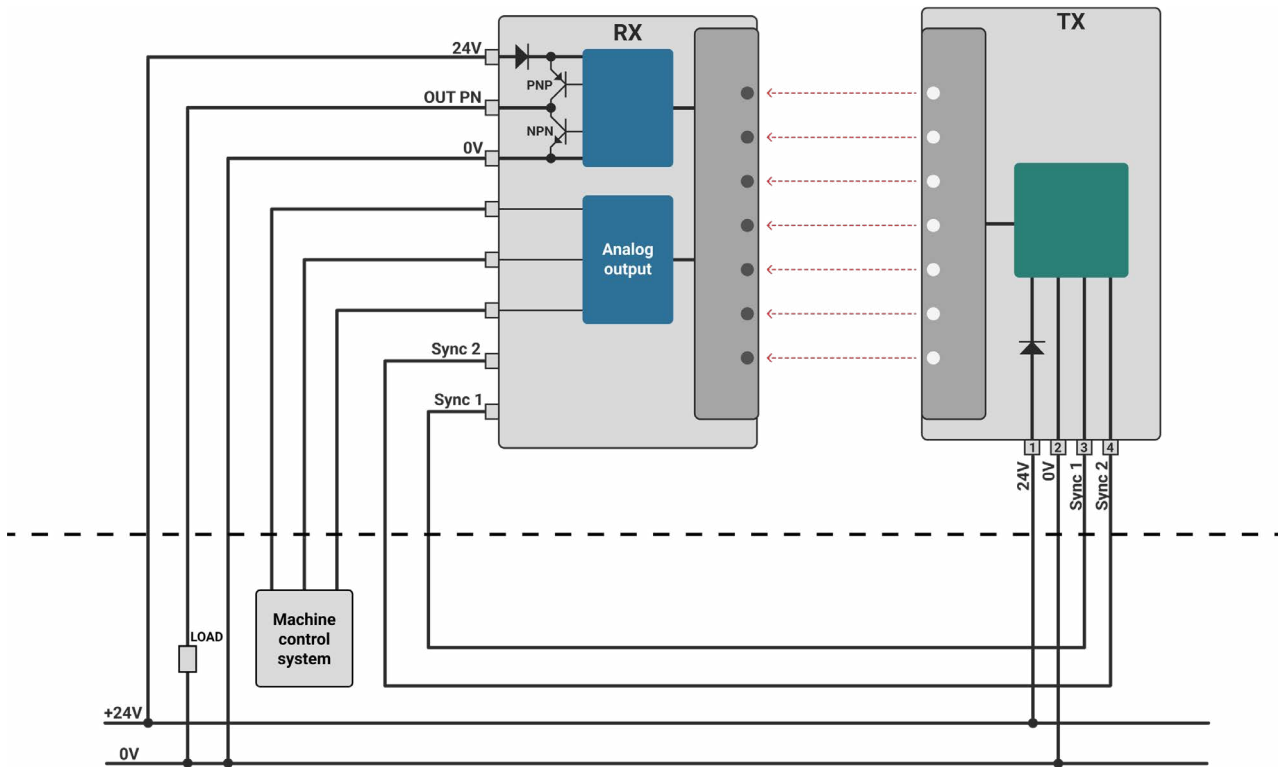

7.2 8PME

RA SL 2AN1 PN 8PME or RA SL 2AN2 PN 8PME

Two analog outputs + PNP/NPN output + Auto-Calibration input.

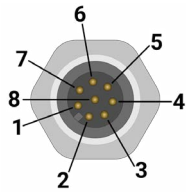

Pin	Colour	RX
1	White	Analog output 1
2	Brown	+24Vdc
3	Green	Out PNP + NPN
4	Yellow	Analog output 2
5	Grey	Analog GND
6	Pink	Auto-Cal
7	Blue	0 Vdc
8	Red	

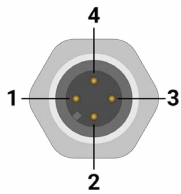

Pin	Colour	TX
1	Brown	+ 24 Vdc
2	White	Sync 1
3	Blue	0 Vdc
4	Black	Sync 2

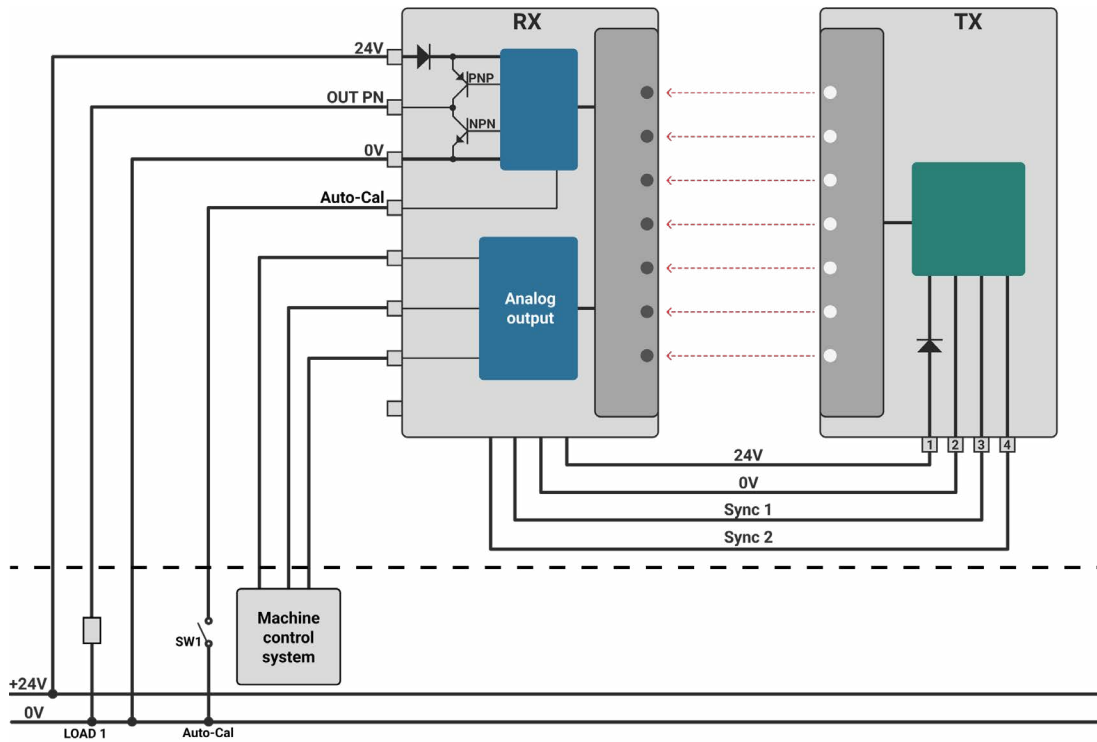

8.1 Common Technical Characteristics

Supply voltage	24Vdc +/- 20%
Power consumption	300mA max, without load
Protection level	IP65
External protection	Polycarbonate, Glass
Status LED	The YELLOW LED on the TX indicates that the device is powered on The RED/GREEN LED on the RX indicates whether the detection area is free (GREEN) or occupied (RED)
Output PN	80mA max, protected against short circuits
Light immunity	200 Klux until L1, 50 Klux above L1

8.2 Identification Code

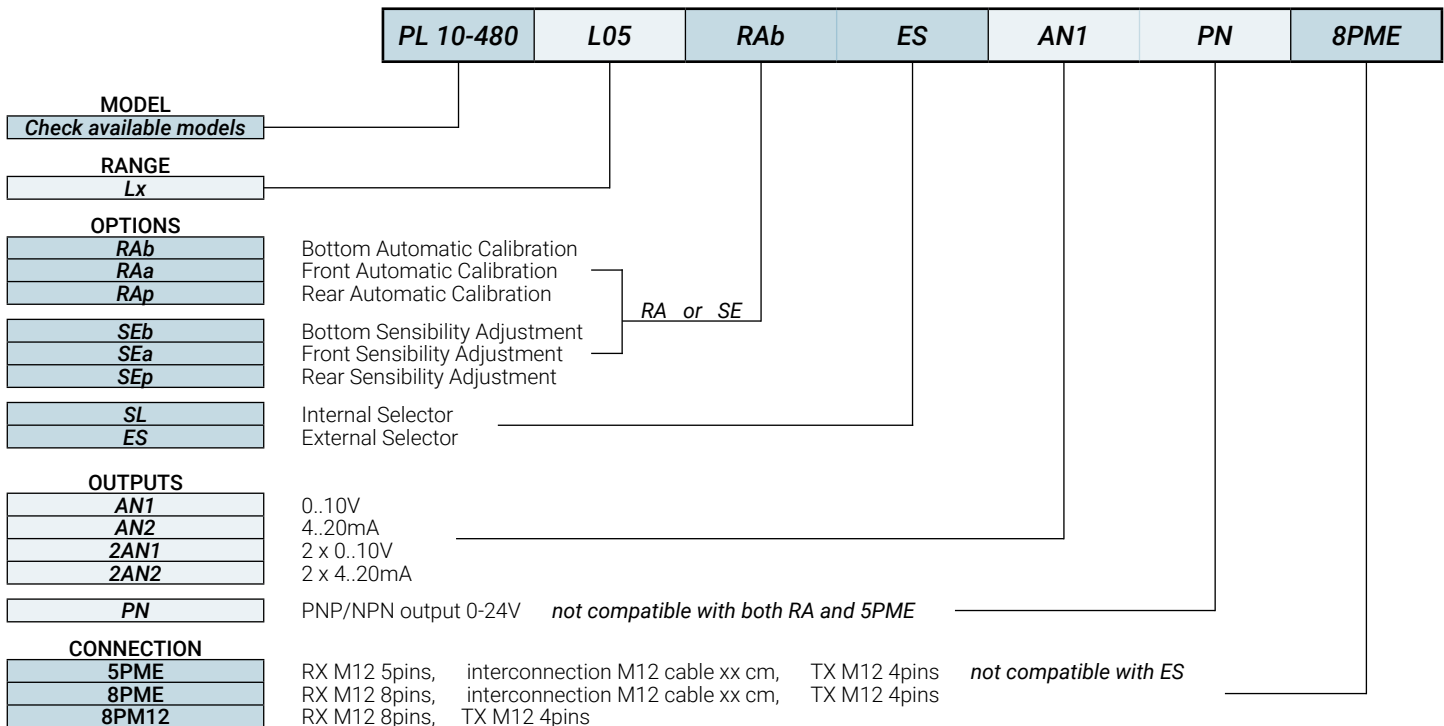

CODE	OPTIONS				OUTPUTS					CONNECTIONS		
	SE	RA	SL	ES	AN1	AN2	2AN1	2AN2	PN	5PME	8PME	8PM12
SE SL AN1 PN 5PME	●		●		●				●	●		
SE SL AN2 PN 5PME	●		●			●			●	●		
RA SL AN1 5PME		●	●		●					●		
RA SL AN2 5PME		●	●			●				●		
SE SL AN1 PN 8PM12	●		●		●				●			●
SE SL AN2 PN 8PM12	●		●			●			●			●
RA SL AN1 PN 8PM12		●	●		●				●			●
RA SL AN2 PN 8PM12		●	●			●			●			●
SE SL AN1 PN 8PME	●		●		●				●		●	
SE SL AN2 PN 8PME	●		●			●			●		●	
RA SL AN1 PN 8PME		●	●		●				●		●	
RA SL AN2 PN 8PME		●	●			●			●		●	
SE ES AN1 PN 8PM12	●			●	●				●			●
SE ES AN2 PN 8PM12	●			●		●			●			●
SE ES AN1 PN 8PME	●			●	●				●		●	
SE ES AN2 PN 8PME	●			●		●			●		●	
RA ES AN1 PN 8PME		●		●	●				●		●	
RA ES AN2 PN 8PME		●		●		●			●		●	
SE SL 2AN1 PN 8PM12	●		●				●		●			●
SE SL 2AN2 PN 8PM12	●		●					●	●			●
SE SL 2AN1 PN 8PME	●		●				●		●		●	
SE SL 2AN2 PN 8PME	●		●					●	●		●	
RA SL 2AN1 PN 8PME		●	●				●		●		●	
RA SL 2AN2 PN 8PME		●	●					●	●		●	

For **SE** and **RA** options, specify the trimmer position; **b** (standard), **a** or **p**. For more information on trimmer positions, refer to the [Options](#) section of the document.

9.1 KPL02 Mounting Bracket Kit

Mounting bracket kit for barriers, particularly suitable for barriers larger than 500mm. The barrier can be locked using the supplied screw and fixed laterally or using an additional M4 screw to fix the barrier at the back.

For best stability, it is recommended to position the brackets near the lower and upper caps.

The KPL02 kit contains:

- 4 PL02 stainless steel brackets
- 4 hexagonal head screws 5 x 50
- 4 M5 nuts

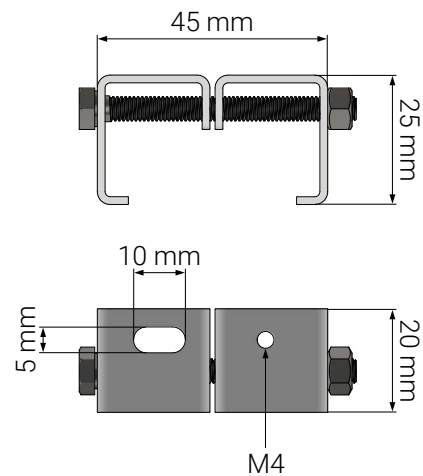

9.2 Connecting Cables

Available cables:

Code	Length	Description
CAV-F4P-M12D-5m	5m	Cable M12 4pins, female, straight, PVC, unshielded
CAV-F4P-M12D-10m	10m	
CAV-F4P-M12D-15m	15m	
CAV-F4P-M12D-20m	20m	
CAV-F4P-M12D-25m	25m	
CAV-F4P-M12D-30m	30m	
CAV-F5P-M12DS-5m	5m	Cable M12 5pins, female, straight, PVC, shielded
CAV-F5P-M12DS-10m	10m	
CAV-F5P-M12DS-15m	15m	
CAV-F8P-M12D-5m	5m	Cable M12 8pins, female, straight, PVC, unshielded
CAV-F8P-M12D-10m	10m	
CAV-F8P-M12D-15m	15m	

10.1 Mechanical Fixing

Polaris series barriers are extremely easy to install. You can choose either threaded hole mounting or **KPL02** bracket mounting (sold separately).

Threaded hole mounting:

Position the receiver and transmitter parallel to each other at the desired distance, within the limits indicated on the label. Secure each one to a sufficiently stable part of the machine using the four threaded holes provided on the caps.

The center-to-center distance "*i*" corresponds to $h - 7\text{ mm}$.

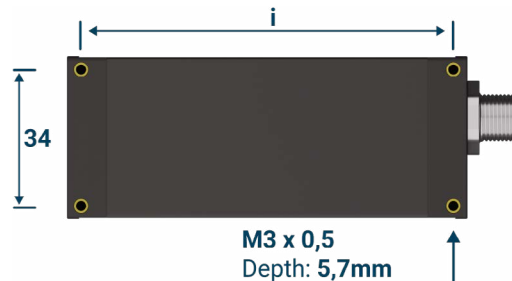

KPL02 bracket mounting:

The KPL02 kit consists of two brackets for the receiver and two for the transmitter.

Once the brackets are secured to the two housings, place RX and TX at the desired distance, compatible with the limits indicated on the label.

Secure each one to a sufficiently stable part of the machine using the threaded holes or slots on the brackets.

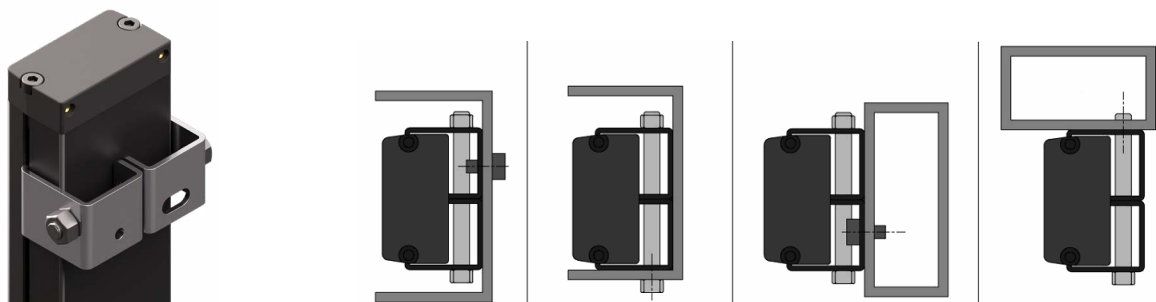

10.2 SE - Sensibility Adjustment

Locate the trimmer on the transmitter based on the chosen code.

Adjust the trimmer until the green LED on the receiver turns on, increasing the margin necessary for vibration immunity and any possible dust deposit on the optical part.



SEb



SEa



SEp

10.3 Automatic Calibration procedure for barriers with RA option

Mount the transmitter and receiver at a distance within the range indicated on the label.

Self-adjustment can be started via a 0/24V signal from a PLC output or N.O. contact.

To activate Auto-Calibration:

- Make sure that there is no material to be detected or other obstacles in the detection area.
- Power on the barriers.
- Send a 0V signal to the autocal input from the PLC or close the SW1 contact for at least 0.5 seconds and no more than 3 seconds.

If the procedure is activated correctly, the yellow LED on the transmitter flashes quickly until the procedure is finished. On the receiver, the green LED turns on for 5 seconds and then flashes red/green until the auto-calibration is finished.

If the green LED does not turn on, check that there are no obstacles in the detection area and that the distance between TX and RX is within the range indicated on the label.

If at the end of the auto-calibration the yellow LED on the transmitter flashes every second, it means that the signal is too strong and the detection may not be optimal, to improve detection increase the distance between the barriers.

The self-adjustment time varies depending on the number of beams of the barrier, approximately the time taken is $0.4 \text{ seconds} * N \text{ beams}$.

For the control of overlapping transparent sheets, it is necessary to start the self-adjustment with the presence of a single transparent sheet in the detection area.

To detect the thinnest and most transparent films, it is necessary that the power adjustment trimmer on the transmitter is set to the minimum, by rotating it completely counterclockwise. Rotating it clockwise slightly increases the power, making the system more stable to environmental variations but reducing the ability to detect the most transparent objects. The adjustment is divided into 6 levels, the set level is indicated by the number of flashes of the yellow LED.

If necessary for tests or particular operating conditions, the self-adjustment function can be eliminated by keeping the SW1 contact closed for more than 3 seconds.

10.4 Output modes with SL option

The analog output provides a variation in voltage or current, in proportion to the position or number of beams interrupted.

Barrier with **SL** option are provided with one or two DIP switch to select four different output mode.

Available are single 0-10 V (**AN1**) or 4-20 mA (**AN2**) outputs, or dual 0-10 V (**2AN1**) or 4-20 mA (**2AN2**) outputs.



Switch		FIR	i-FIR	LIR	TIR
	1	OFF	OFF	ON	ON
	2	OFF	ON	ON	OFF

FIR: Provides the value of the first interrupted beam starting from the bottom (connector side). Suitable for determining the position.

i-FIR: Provides the value of the first interrupted beam starting from the top (opposite side of the connector). Suitable for determining the position.

LIR: Provides the value of the last interrupted beam starting from the bottom (connector side). Suitable for determining the height of objects, e.g. in packaging systems.

TIR: Provides the total number of interrupted beams. Suitable for determining the size of objects. Suitable for determining the dimensions of objects.

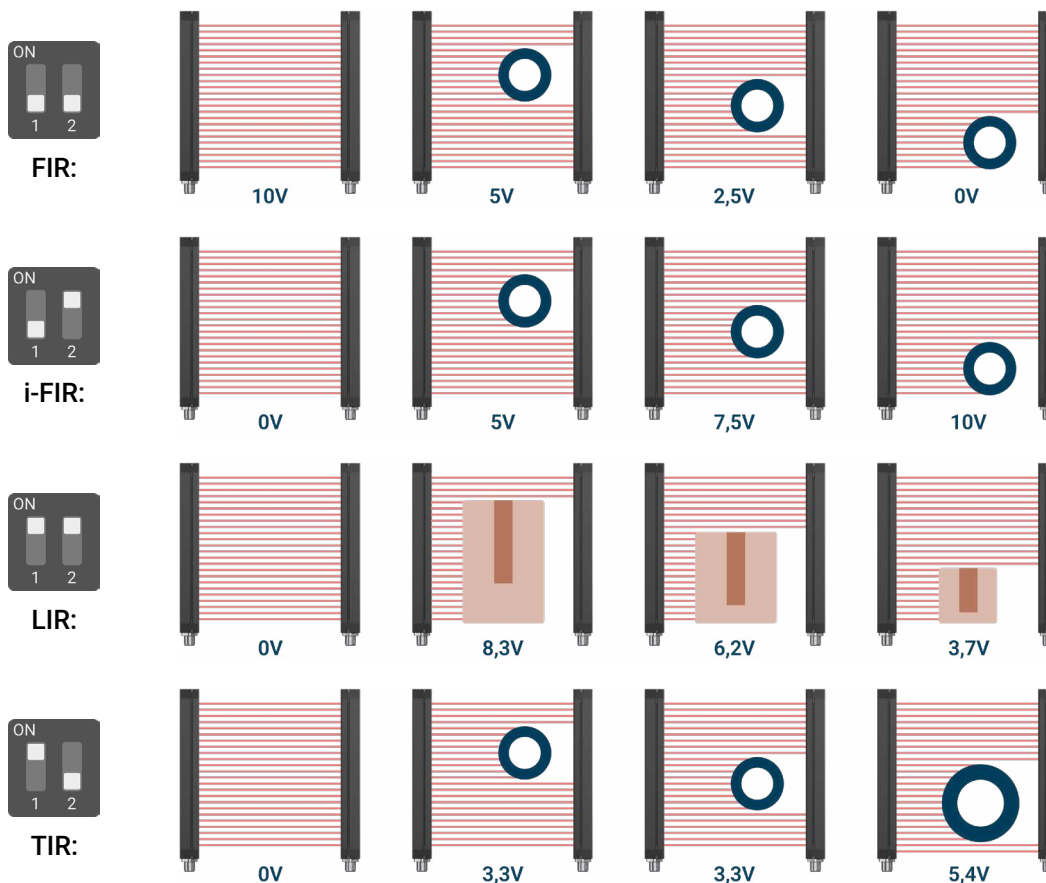

10.5 Output modes with ES option

The analog output provides a variation in voltage or current, in proportion to the position or number of beams interrupted.

With the external wire (**ES**) option can select three output mode using a wire of the M12 connector.

Available are single 0-10 V (**AN1**) or 4-20 mA (**AN2**) outputs.

- FIR:** Provides the value of the first interrupted beam starting from the bottom (connector side). Suitable for determining the position.
- LIR:** Provides the value of the last interrupted beam starting from the bottom (connector side). Suitable for determining the height of objects, e.g. in packaging systems.
- TIR:** Provides the total number of interrupted beams. Suitable for determining the size of objects.

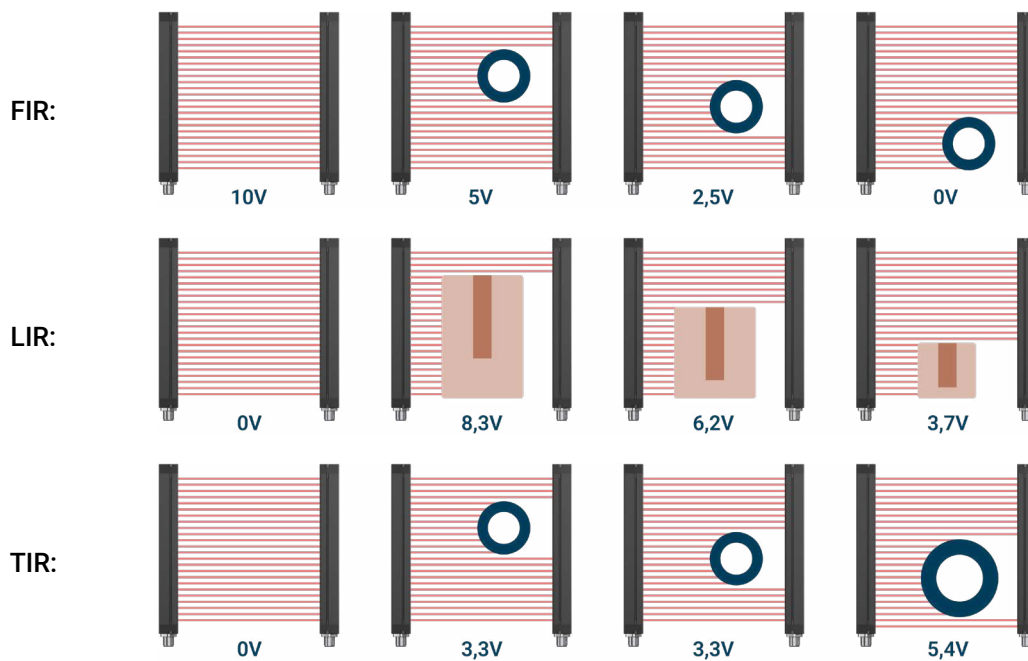

To correctly set these modes, see the connection diagram in the [Connections](#) section.



Via Papa Giovanni XXIII, 16
20099
Sesto San Giovanni, Milan
Italy



www.optoscan.it/en



+39 0243122115



info@optoscan.it